

how computers work (3)

inside the ALU

the arithmetic and logic unit

recall: the ALU

- takes as *input* some *data* (bits) from some *registers*
- performs an *operation* on the data, such as addition, subtraction, multiplication, division
- produces the *output* of the operation

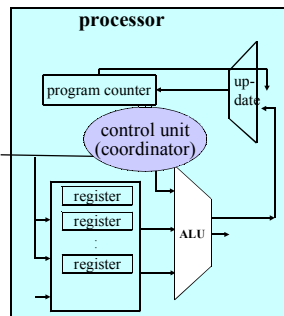

goals

- last time, we saw the fetch/execution cycle
- focus was on
 - flow of instructions and data between memory and the computer processor
 - the units within the processor and their roles
- today: see how one component, the ALU (arithmetic and logic unit) works

our task: design a unit that adds 1 to a 2-bit input

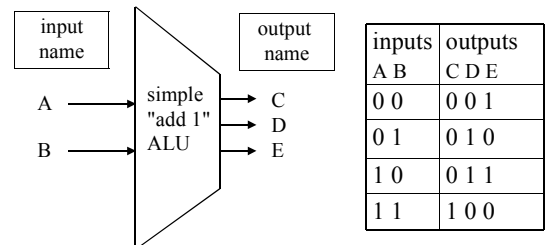

Note: the function of our "add-1" ALU can be specified as an input/output table

basic building block for the ALU

- the ALU (as well as the control unit and the unit that updates the program counter) are built from components called *gates*
- a versatile gate is the *NAND gate*, which takes two input signals (bits) and produces a single output bit:

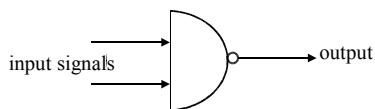

NAND gate

there are four possible input values:

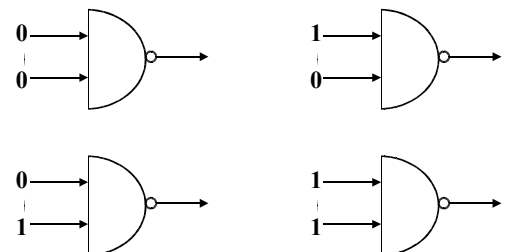

NAND gate

for these input values, the output value is:

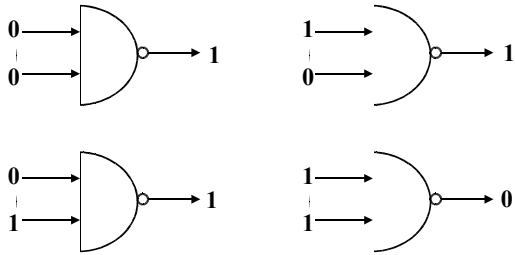

NAND gate

the NAND gate's function can be summarised in a table:

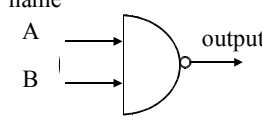

input A	input B	output
0	0	1
0	1	1
1	0	1
1	1	0

circuits

- just as brains are built from brain cells (called neurons), *circuits* are built from gates
- here is a circuit with two inputs and two gates; what is its input output table?

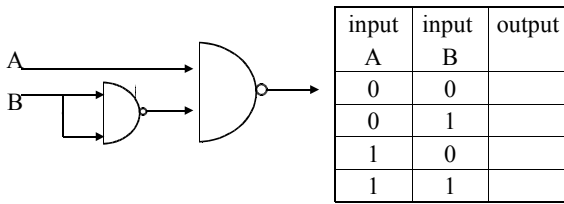

circuits

- just as brains are built from brain cells (called neurons), *circuits* are built from gates
- here is a circuit with two inputs and two gates; what is its input output table?

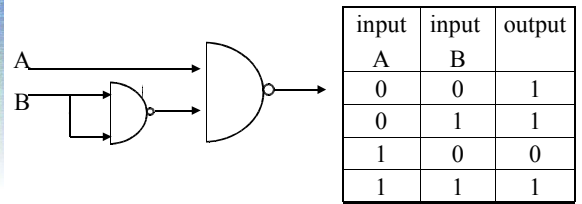

more circuits

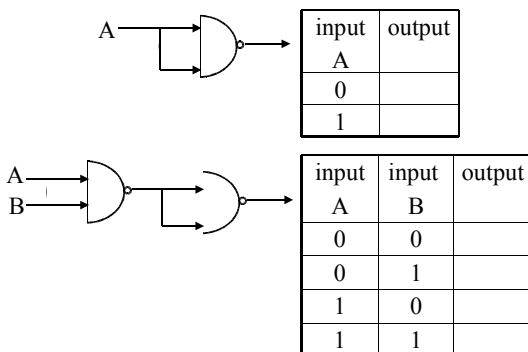

more circuits

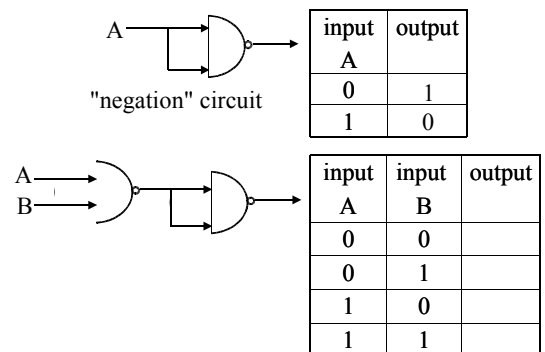

more circuits

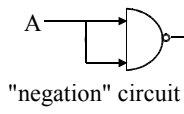

input A	output
0	1
1	0

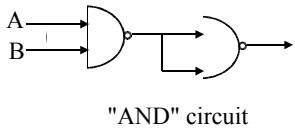

input A	input B	output
0	0	0
0	1	0
1	0	0
1	1	1

the EXOR circuit: what is its table?

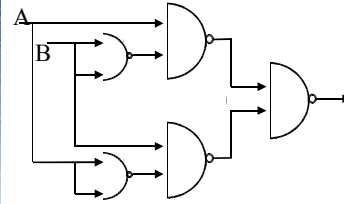

input A	input B	output
0	0	
0	1	
1	0	
1	1	

the EXOR circuit: what is its table?

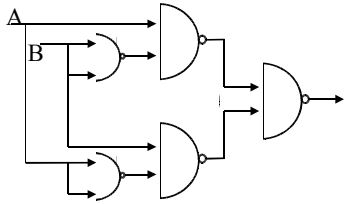

input A	input B	output
0	0	0
0	1	1
1	0	1
1	1	0

an abstraction of the EXOR circuit:

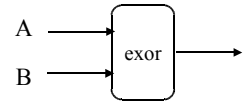
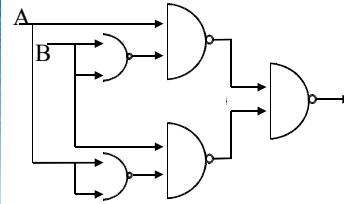

back to our task: first focus on output C

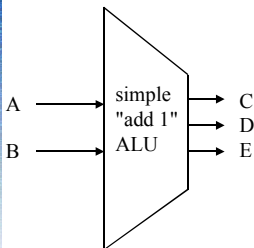

inputs AB	outputs CDE
00	001
01	010
10	011
11	100

back to our task: first focus on output E

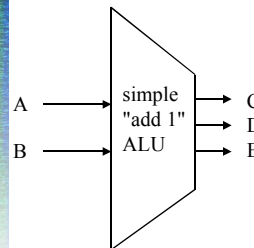

inputs AB	outputs CDE
00	1
01	0
10	1
11	0

output E is the negation of input B!

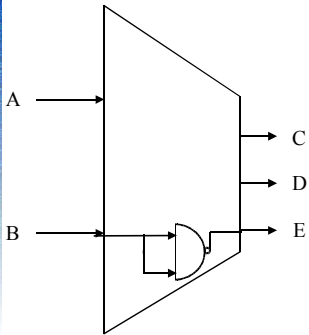

inputs	outputs
A B	C D E
0 0	0 0 1
0 1	0 1 0
1 0	0 1 1
1 1	1 0 0

next look at output D

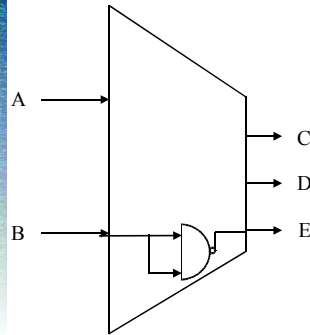

inputs	outputs
A B	C D E
0 0	0 0 1
0 1	0 1 0
1 0	0 1 1
1 1	1 0 0

next look at output D

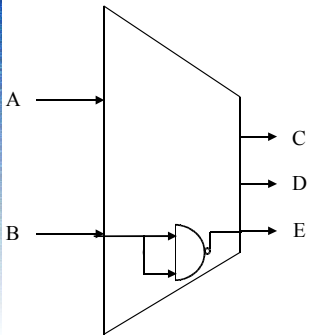

inputs	outputs
A B	C D E
0 0	0
0 1	1
1 0	1
1 1	0

output D is the EXOR of inputs A and B

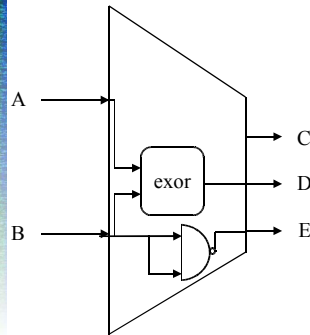

inputs	outputs
A B	C D E
0 0	0 0 1
0 1	0 1 0
1 0	0 1 1
1 1	1 0 0

finally, look at output C

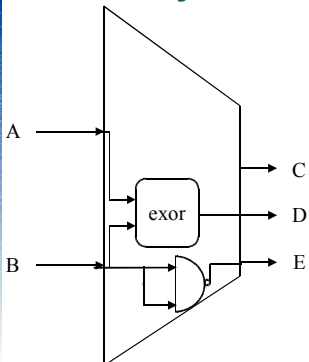

inputs	outputs
A B	C D E
0 0	0 0 1
0 1	0 1 0
1 0	0 1 1
1 1	1 0 0

output C is the AND of inputs A and B

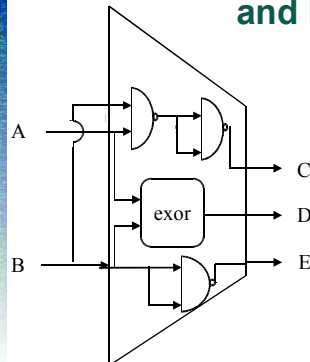

inputs	outputs
A B	C D E
0 0	0 0 1
0 1	0 1 0
1 0	0 1 1
1 1	1 0 0



summary

- a circuit that adds 1 to a binary number can be built from NAND gates
- circuits that add or multiply two binary numbers are based on exactly the same principles
- you can buy NAND gates online! 43 cents for 4 NAND gates on a chip at www.semiconductors.philips.com